

LT2–B847Mark II

Twin Needle Drop Feed Lock Stitcher
Twin Needle Drop Feed Lock Stitcher
with Thread Trimmer



Specifications

		-1
Application		For thin materials
Max. speed		4,000 rpm
Max. stitch length		4 mm
Needle bar stroke		33.4 mm
Thread take-up stroke		49.9 mm
Height of presser foot	Presser bar lifter	7 mm
	Knee lifter	13 mm (With thread wiper: 10 mm)
Height of feed dog		1 mm
Needle		DP×5 #9 – #14
Hook		Horizontal rotary hook (vertical axis)
		-400
Thread trimmer		Scissors type (Solenoid)
Thread wiper		Solenoid type
Quick reverse		Solenoid type

B847 Mark II (For Standard)

For normal



*In case of using over 1-1/2" (38.1 mm) gauge parts, it is necessary to make special machining on the arm-bed.

The specification with a maximum stitch width of 77 mm is available.

Please consult your Brother representative concerning delivery date and price.

*The O symbol is a presser foot assembly with finger guard.

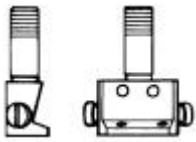
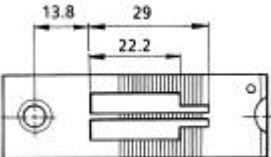
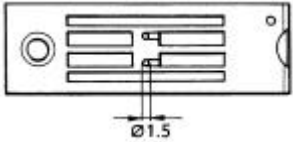
Needle gauge (inch) (mm)	Needle clamp assy	Needle plate		Feed dog		Presser foot assy	
		(-1) For light materials	For new synthetic fiber	(-1) For light materials	For new synthetic fiber	(-1) For light materials	For new synthetic fiber
1/8 (3.2)	158794-101	S07686-001		S07696-001		S07393-001 S38544-001 O	
3/16 (4.8)	158791-101	S07688-001	S36842-001	S07698-001	S36838-001	S07395-001 S38542-001 O	S36839-001
1/4 (6.4)	158792-101	S07689-001	S36841-001	S07699-001	S36835-001	S07397-001 S38543-001 O	S36836-001
1/2 (12.7)	158797-101	S07693-001		S07703-001		S07684-101 O	
3/4 (19.1)	158806-101	S07996-001		S07998-001		S07889-101 O	
20mm	S00937-001	S13479-001		S07998-001		S13480-101 O	
7/8 (22.2)	158807-101	S07997-001	S37011-001	S07999-001	S07999-001	S07894-101 O	S37012-001

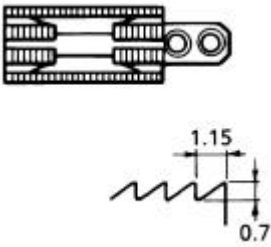
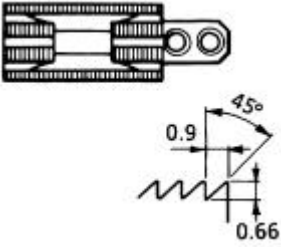
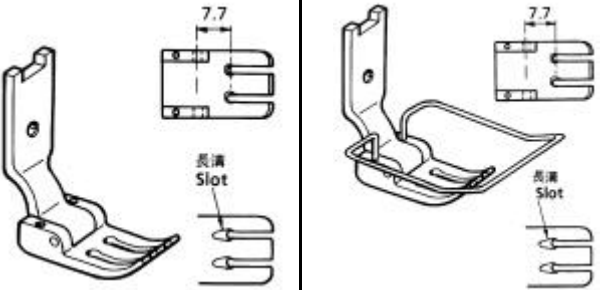
Needle clamp assy	Needle plate		Presser foot assy	
	(-1) For light materials	For new synthetic fiber	For new synthetic fiber	
				
Feed dog		Presser foot assy		
(-1) For light materials	For new synthetic fiber	(-1) For light materials		
				

B847 Mark II (For Standard)

For shirt fronts

*The ○ symbol is a presser foot assembly with finger guard.

Needle gauge mm	Needle clamp assy	Needle plate	Feed dog	Presser foot assy
		(-1) For light materials	(-1) For light materials	(-1) For light materials
18mm	S14352-001	S14354-001	S14357-001	S14355-101 ○
20mm	S00937-001	S13479-001	S14360-001	S14358-101 ○
22mm	158807-001	S07997-001	S14363-001	S14361-101 ○
24mm	S14364-001	S14366-001	S14369-001	S14367-101 ○
26mm	S14370-001	S14372-001	S14375-001	S14373-101 ○
28mm	S14376-001	S14378-001	S14381-001	S14379-101 ○
30mm	S16651-001	S16653-001	S16656-001	S16654-101 ○

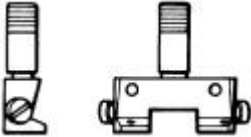
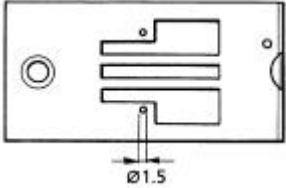
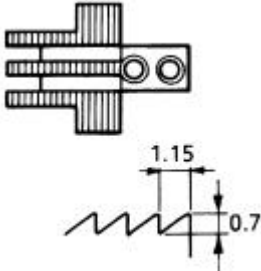
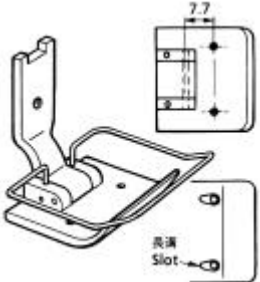
Needle clamp assy	Needle plate	Feed dog	Presser foot assy
	(-1) For light materials	(-1) For light materials	(-1) For light materials
			

B847 Mark II (For Thread trimmer)

For normal

*The thread trimming fixed knife (part No. S07527-001) and the installation screw (part No. 148539-101) are not provided with the needle plate, so they must be ordered separately if required.

*In case of using over 1-1/2" (38.1 mm) gauge parts, it is necessary to make special machining on the arm-bed. The specification with a maximum stitch width of 77 mm is available.

Please consult your Brother representative concerning delivery date and price.

*The O symbol is a presser foot assembly with finger guard.

Needle gauge (inch) (mm)	Needle clamp assy	Needle plate		Feed dog		Presser foot assy	
		(-) For light materials	For new synthetic fiber	(-) For light materials	For new synthetic fiber	(-) For light materials	For new synthetic fiber
1/8 (3.2)	158794-101	S07401-001		S07409-001		S07393-001 S38544-001 O	
3/16 (4.8)	158791-101	S07403-001	S36844-001	S07410-001	S36843-001	S07395-001 S38542-001 O	S36839-001
1/4 (6.4)	158792-101	S07405-001	S36847-001	S07411-001	S36846-001	S07397-001 S38543-001 O	S36836-001
5/16 (7.9)	158793-101	S07676-001		S07680-001		S07682-001	
3/8 (9.5)	158798-101	S13621-001		S13623-001		S13624-001	
1/2 (12.7)	158797-101	S07678-001		S07681-001		S07684-101 O	
3/4 (19.1)	158806-101	S07886-001		S07888-001		S07889-101 O	
7/8 (22.2)	158807-101	S07891-001	S37014-001	S07893-001	S07893-001	S07894-101 O	S37012-001
1 (25.4)	158805-101	S15088-001		S15090-001		S15091-101 O	
1-1/4 (38.1)	158799-001	S20914-001		S20916-001		S20917-101 O	

Needle clamp assy	Needle plate		Presser foot assy	
	(-) For light materials	For new synthetic fiber	For new synthetic fiber	
Feed dog		Presser foot assy		
(-) For light materials	For new synthetic fiber	(-) For light materials		